



جدول مشخصات فنی ترانسفورماتورهای کم تلفات AB'

Standard Accessories of Distribution Transformer						
No.	Accessory	Power (kVA)				
		25-160	200-315	400-500	630-800	1000-2000
1	HV bushing	•	•	•	•	•
2	Arcing horns	•	•	•	•	•
3	LV bushing	•	•	•	•	•
4	Oil level indicator	•	•	•	•	•
5	Buchholz relay	-	-	-	-	•
6	Oil drain & sampling valve	•	•	•	•	•
7	Earthing bolt	•	•	•	•	•
8	Wheel	-	-	•	•	•
9	Off circuit tap changer	•	•	•	•	•
10	Name plate	•	•	•	•	•
11	Oil temperature indicator	-	-	-	•	•
12	Conservator tank drain valve	•	•	•	•	•
13	Conservator	•	•	•	•	•
14	Conservator filling plug	•	•	•	•	•
15	Thermometer pocket	-	•	•	•	•
16	Dehydrating breather	•	•	•	•	•

• Applied accessory



Notes:

- For other electrical characteristics, dimensions and weights, please consult us.
- Ask for confirmation of the information given in this publication. Present document will bind us only after confirmation from Marketing & Sales department.

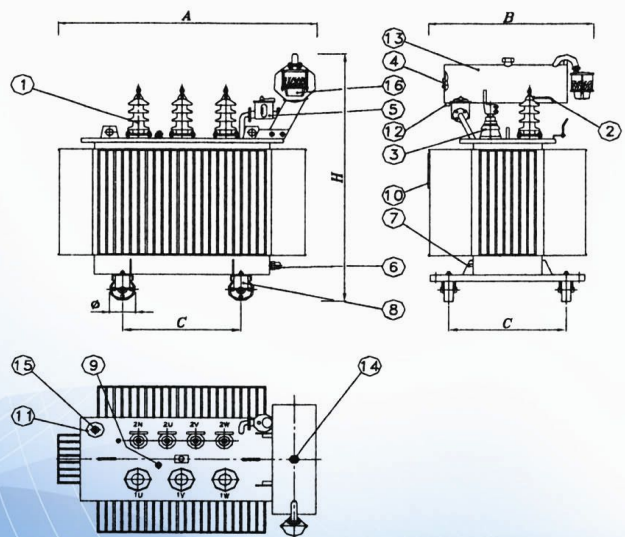

۱۵ سال سابقه تامین انواع تجهیزات توزیع برق
۱۵ سال سابقه تامین انواع تجهیزات توزیع برق